

# Rolling Grit— Grit Removal System

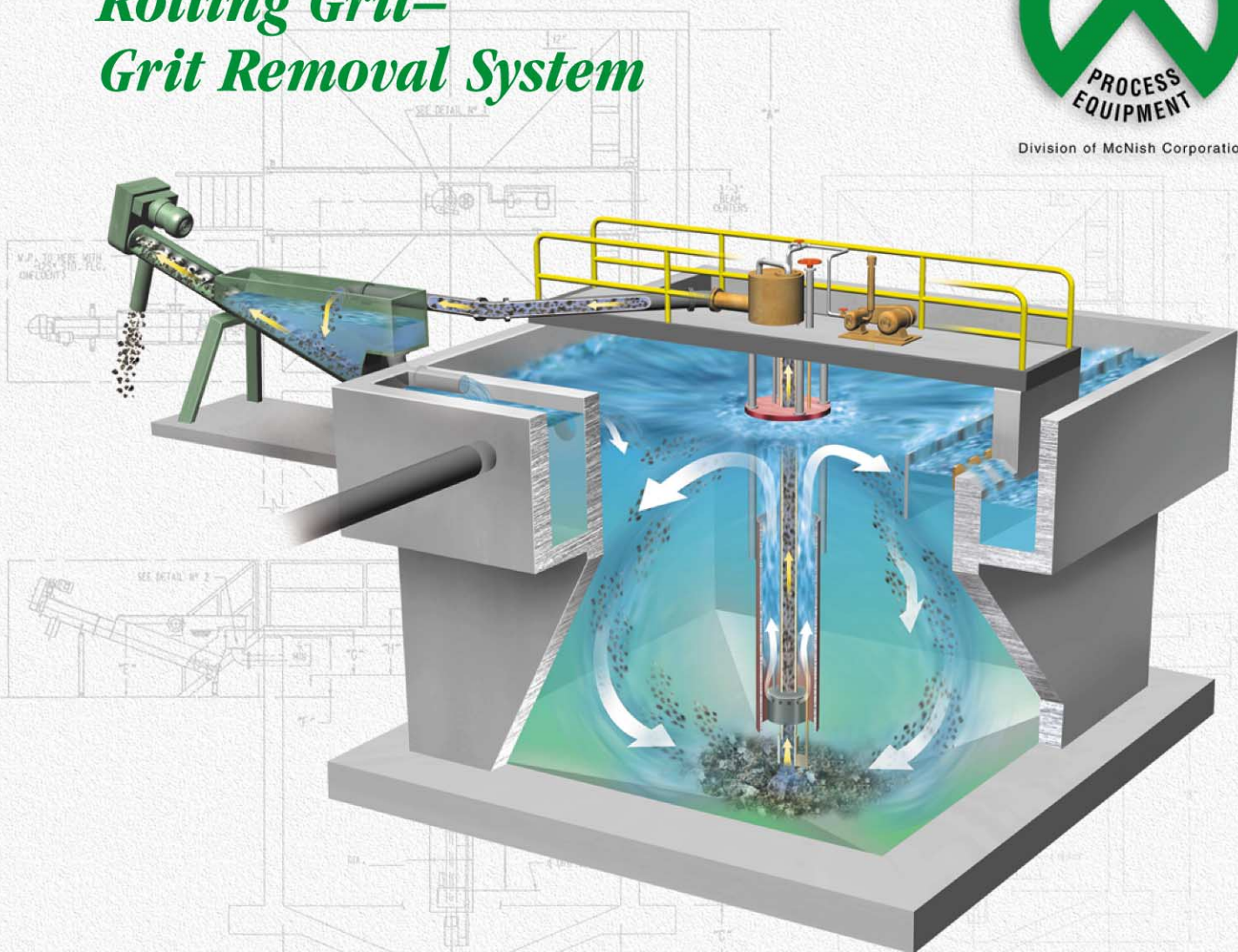

Division of McNish Corporation



## Pre-aeration, Grit Removal and Dewatering in One System with No Underwater Moving Parts

The easy to install, easy to maintain **Rolling Grit from Walker Process Equipment** provides a means to pre-aerate, remove grit and dewater in a low energy system with no underwater moving parts.



### Rolling Grit by Walker Process:

- Provides aeration to “freshen” the incoming sewage flow.
- Has no mechanical equipment or moving parts in the grit flow stream, eliminating maintenance due to wear; no chain, no mixers, and no pumps.
- Is easily adjusted to the plant flow and loading conditions.
- Is non-flow sensitive—low flow conditions won’t turn the grit collector into a primary clarifier.
- Has low hydraulic head loss through the unit.
- Has low energy requirements—in many cases existing plant air can be utilized.
- Features a Hot-Dip Galvanized finish; stainless steel construction is available for extra corrosion resistance.

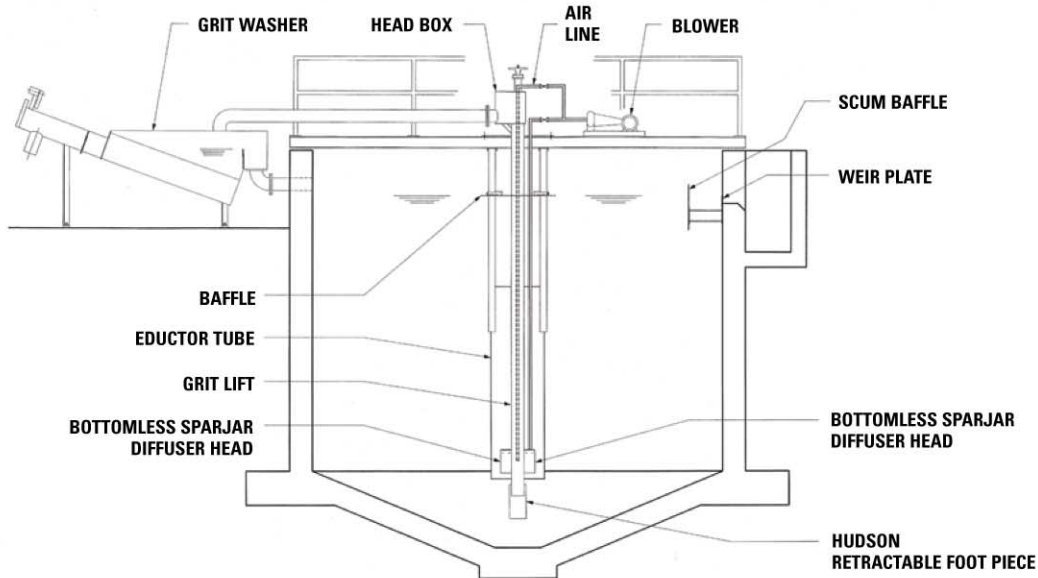

## Simplicity, Efficiency and Superior Grit Removal

The **Walker Process Rolling Grit System** provides a complete system for pre-aeration, grit removal and dewatering. A centrally located eductor tube with swirl vanes induces a rolling action that also rotates the contents about a vertical axis. This effectively separates grit from organic material and maintains those organics in suspension. Settled grit is carried to a center hopper where an airlift pump transfers the grit to an inclined screw Grit Washer located outside the basin. The grit lift is provided with an adjustable foot piece that may be manually raised or lowered depending on the level of grit accumulation in the hopper.

Mechanical grit pumps may be used in lieu of the standard airlift pump for situations that require a high freeboard.

### Tank Sizes/Peak Flow

8' x 8' x 10' swd	To 1,050 gpm
10' x 10' x 12' swd	1,600 gpm
12' x 12' x 12' swd	2,300 gpm
14' x 14' x 12' swd	3,200 gpm
16' x 16' x 12' swd	4,200 gpm
18' x 18' x 14' swd	5,200 gpm
21' x 21' x 14' swd	7,000 gpm
24' x 24' x 14' swd	9,250 gpm
30' x 30' x 14' swd	14,400 gpm

### Capacities

From below 1,050 gpm to over 10,000 gpm in single basins. Designs for multiple unit basins are available.

### Surface Rate

16 gpm/sq. ft. at peak flow.

### Detention Time

5-6 minutes at peak flow.

### Grit Washer

Rugged solid-shaft screw conveyor with a 9" x 2/3 pitch screw conveyor, with a 3/4 HP drive and either a coated carbon steel or stainless steel trough and housing.

### Blower

Positive Displacement type 3.0 to 15.0 HP depending on basin size

## Walker Process Equipment

Division of McNish Corporation

840 North Russell Avenue • Aurora, IL 60506 • Phone: 630-892-7921 • Fax: 630-892-7951

E-mail: [walker.process@walker-process.com](mailto:walker.process@walker-process.com)

[www.walker-process.com](http://www.walker-process.com)